

# SP01 Series Shielded Power Inductors

## Features

- Magnetically shielded construction
- Ideal inductors for DC-DC conversion
- Low profile with low DCR and high current
- Available on tape and reel for auto surface mounting

## Applications

- Power supplies
- Noise filtering and filter chokes
- DC-DC converters, etc.
- Other various electronic appliances

## Environmental Data

- Storage temperature range: -40°C to +125°C
- Operating temperature range: -40°C to +125°C (including coil's self-temperature rise)
- Solder reflow temperature: +260°C Max for 10 seconds Max
- Moisture sensitivity level: 1
- RoHS&HF compliance



## Packaging

- Supplied in tape and reel packaging, 2500pcs(SP01-0603), 1200pcs(SP01-1003), 1000pcs(SP01-1004), 750pcs(SP01-1005), per 13-inch reel

## Mechanical Dimension (Unit: mm/inches)

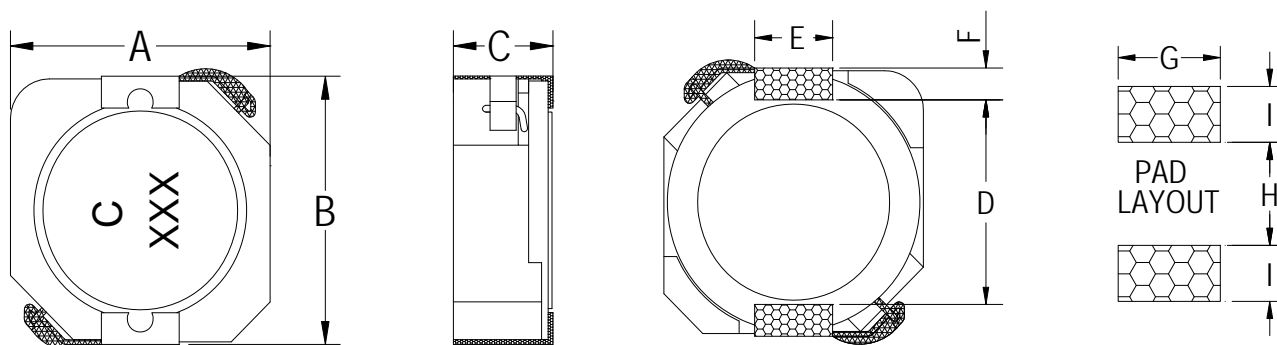

Type	A Max.	B Max.	C Max.	D Nom.	E Nom.	F Nom.	G Nom.	H Nom.	I Nom.
SP01-0603	6.2/.244	6.3/.248	3.0/.118	4.7/.185	2.0/.079	0.6/.024	2.6/.102	4.6/.181	1.0/.040
SP01-1003	10.3/.406	10.5/.413	3.0/.118	7.9/.311	3.0/.118	1.2/.047	3.6/.142	7.3/.287	1.7/.067
SP01-1004	10.3/.406	10.5/.413	4.0/.158	7.9/.311	3.0/.118	1.2/.047	3.6/.142	7.3/.287	1.7/.067
SP01-1005	10.3/.406	10.5/.413	5.0/.197	7.9/.311	3.0/.118	1.2/.047	3.6/.142	7.3/.287	1.7/.067

## Electrical Schematic

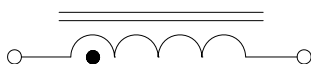

## Part Number Description

SP01 - 0603 2R5 N

① ② ③ ④

- ① Type
- ② Dimensions
- ③ Inductance value
- ④ Tolerance code

# SP01 Series Shielded Power Inductors

## Electrical Characteristic

Part Number	Inductance L0(uH)	Test Freq. (KHz)	DC Resistance (mΩ)Max.	Isat (A)Typ.	Irms (A)Typ.	Marking
SP01-06032R5N	2.5	100	17.6	2.60	2.60	C2R5
SP01-06033R3N	3.3	100	20.3	2.30	2.30	C3R3
SP01-06034R0N	4.0	100	27.0	2.10	2.10	C4R0
SP01-06035R0N	5.0	100	31.1	1.85	1.85	C5R0
SP01-06036R0N	6.0	100	41.9	1.70	1.70	C6R0
SP01-06038R0N	8.0	100	49.9	1.50	1.50	C8R0
SP01-0603100N	10	100	54.0	1.30	1.30	C100
SP01-0603120M	12	100	71.6	1.20	1.20	C120
SP01-0603150M	15	100	82.4	1.10	1.10	C150
SP01-0603180M	18	100	101.5	1.05	1.05	C180
SP01-0603220M	22	100	119.0	0.95	0.95	C220
SP01-0603270M	27	100	146.0	0.85	0.85	C270
SP01-0603330M	33	100	182.5	0.76	0.76	C330
SP01-0603390M	39	100	209.5	0.68	0.68	C390
SP01-0603470M	47	100	229.5	0.60	0.60	C470
SP01-0603560M	56	100	305.0	0.55	0.55	C560
SP01-0603680M	68	100	351.0	0.48	0.48	C680
SP01-0603820M	82	100	418.5	0.45	0.45	C820
SP01-0603101M	100	100	520.0	0.40	0.40	C101

- Tolerance of Inductance:K= ±10%,M= ±20%,N= ±30%.
- All test data referenced to 25°C ambient.
- Saturation current(Isat) will cause L0 to drop 30% typical.
- Heat rated current(Irms) will cause the coil temperature rise approximately Δt of 40°C.

# SP01 Series Shielded Power Inductors

## Electrical Characteristic

Part Number	Inductance L0(uH)	Test Freq. (KHz)	DC Resistance (mΩ)Max.	Isat (A)Typ.	Irms (A)Typ.	Marking
SP01-1003R80N	0.8	100	5.7	9.00	6.50	CR80
SP01-10031R5N	1.5	100	11.0	7.00	4.20	C1R5
SP01-10032R2N	2.2	100	16.9	5.80	4.05	C2R2
SP01-10033R3N	3.3	100	21.0	4.60	3.80	C3R3
SP01-10034R7N	4.7	100	30.0	4.00	3.30	C4R7
SP01-10036R8N	6.8	100	35.0	3.20	3.15	C6R8
SP01-10038R2N	8.2	100	50.0	3.00	2.50	C8R2
SP01-1003100N	10	100	58.1	2.70	2.40	C100
SP01-1003120M	12	100	72.1	2.40	2.10	C120
SP01-1003150M	15	100	86.5	2.20	2.05	C150
SP01-1003180M	18	100	116.1	2.00	1.50	C180
SP01-1003220M	22	100	143.0	1.80	1.20	C220
SP01-1003270M	27	100	175.9	1.65	1.15	C270
SP01-1003330M	33	100	202.0	1.48	1.10	C330
SP01-1003390M	39	100	268.9	1.35	1.00	C390
SP01-1003470M	47	100	299.0	1.20	0.90	C470
SP01-1003560M	56	100	325.0	1.15	0.78	C560
SP01-1003680M	68	100	429.0	1.05	0.68	C680
SP01-1003820M	82	100	494.0	0.95	0.63	C820
SP01-1003101M	100	100	683.0	0.85	0.56	C101
SP01-1003121K	120	100	754.0	0.76	0.53	C121
SP01-1003151K	150	100	871.0	0.70	0.51	C151

- Tolerance of Inductance:K= ±10%,M= ±20%,N= ±30%.
- All test data referenced to 25°C ambient.
- Saturation current(Isat) will cause L0 to drop 30% typical.
- Heat rated current(Irms) will cause the coil temperature rise approximately Δt of 40°C.

# SP01 Series Shielded Power Inductors

## Electrical Characteristic

Part Number	Inductance L0(uH)	Test Freq. (KHz)	DC Resistance (mΩ)Max.	Isat (A)Typ.	Irms (A)Typ.	SRF (MHz)Typ.	Marking
SP01-10041R0N	1.0	100	6.0	12.1	10.0	138	C1R0
SP01-10041R5N	1.5	100	8.1	11.06	7.85	81	C1R5
SP01-10042R5N	2.5	100	10	9.26	6.65	61	C2R5
SP01-10043R8N	3.8	100	13	7.64	6.05	45	C3R8
SP01-10045R2N	5.2	100	22	6.14	5.10	37	C5R2
SP01-10047R0N	7.0	100	27	5.60	4.35	33	C7R0
SP01-1004100N	10	100	35	4.52	4.05	29	C100
SP01-1004120M	12	100	41	4.04	4.00	25	C120
SP01-1004150M	15	100	50	3.86	3.80	21	C150
SP01-1004180M	18	100	65	3.52	3.35	18	C180
SP01-1004220M	22	100	73	3.30	2.85	15	C220
SP01-1004270M	27	100	89	2.84	2.35	15	C270
SP01-1004330M	33	100	93	2.62	2.30	13	C330
SP01-100390M	39	100	112	2.34	2.25	12	C390
SP01-1004470M	47	100	128	2.22	2.20	11	C470
SP01-1004560M	56	100	180	2.04	1.85	11	C560
SP01-1004680M	68	100	213	1.82	1.75	10	C680
SP01-1004820M	82	100	261	1.60	1.50	8	C820
SP01-1004101M	100	100	304	1.46	1.45	6	C101
SP01-1004121K	120	100	380	1.34	1.25	6	C121
SP01-1004151K	150	100	506	1.22	1.20	6	C151
SP01-1004181K	180	100	582	1.16	0.98	5	C181
SP01-1004221K	220	100	756	0.99	0.97	5	C221
SP01-1004271K	270	100	926	0.91	0.86	4	C271
SP01-1004331K	330	100	1090	0.82	0.69	4	C331
SP01-1004391K	390	100	1141	0.74	0.65	4	C391
SP01-1004471K	470	100	1243	0.70	0.63	3	C471
SP01-1004561K	560	100	1696	0.56	0.59	3	C561
SP01-1004681K	680	100	1926	0.52	0.50	3	C681
SP01-1004821K	820	100	2596	0.49	0.47	3	C821
SP01-1004102K	1000	100	2853	0.46	0.45	3	C102

- Tolerance of Inductance:K= ±10%,M= ±20%,N= ±30%.
- All test data referenced to 25°C ambient.
- Saturation current(Isat) will cause L0 to drop 30% typical.
- Heat rated current(Irms) will cause the coil temperature rise approximately Δt of 40°C.

# SP01 Series Shielded Power Inductors

## Electrical Characteristic

Part Number	Inductance L0(uH)	Test Freq. (KHz)	DC Resistance (mΩ)Max.	Isat (A)Typ.	Irms (A)Typ.	SRF (MHz)Typ.	Marking
SP01-1005R68N	0.68	100	5.5	13.5	9.50	110	CR68
SP01-10051R2N	1.2	100	7.0	10.5	8.30	85	C1R2
SP01-10052R2N	2.2	100	9.0	8.20	7.20	53	C2R2
SP01-10053R3N	3.3	100	11	7.80	6.50	40	C3R3
SP01-10054R2N	4.2	100	14	6.40	6.10	29	C4R2
SP01-10056R8N	6.8	100	19	5.40	5.40	27	C6R8
SP01-10058R2N	8.2	100	22	4.85	5.00	21	C8R2
SP01-1005100N	10	100	31	4.45	4.50	16.5	C100
SP01-1005120M	12	100	35	4.00	3.80	15	C120
SP01-1005150M	15	100	47	3.60	3.40	14	C150
SP01-1005180M	18	100	51	3.20	3.10	11.0	C180
SP01-1005220M	22	100	62	2.95	2.90	10.5	C220
SP01-1005270M	27	100	77	2.70	2.60	10.0	C270
SP01-1005330M	33	100	93	2.40	2.50	9.0	C330
SP01-1005390M	39	100	106	2.30	2.25	6.8	C390
SP01-1005470M	47	100	127	2.00	2.00	5.9	C470
SP01-1005560M	56	100	160	1.90	1.90	5.5	C560
SP01-1005680M	68	100	208	1.65	1.60	5.0	C680
SP01-1005820M	82	100	230	1.50	1.45	4.5	C820
SP01-1005101M	100	100	255	1.35	1.35	4.2	C101
SP01-1005121K	120	100	305	1.28	1.18	3.8	C121
SP01-1005151K	150	100	370	1.12	1.10	3.6	C151
SP01-1005181K	180	100	420	1.04	1.00	3.4	C181
SP01-1005221K	220	100	500	0.94	0.94	3.0	C221
SP01-1005271K	270	100	675	0.84	0.80	2.4	C271
SP01-1005331K	330	100	815	0.75	0.73	2.0	C331

- Tolerance of Inductance:K= ±10%,M= ±20%,N= ±30%.
- All test data referenced to 25°C ambient.
- Saturation current(Isat) will cause L0 to drop 30% typical.
- Heat rated current(Irms) will cause the coil temperature rise approximately Δt of 40°C.